

REVISIONS				
SYM	ZONE	ECN, ERN NO.	DATE	APPRD.
A		PROPOSAL	2005/01/07	
B		PROPOSAL	MAY12/06	A.K.

THIS IS A CAD DRAWING. DO NOT MANUALLY REVISE.

AMPHENOL PART NUMBER CONFIGURATION:

U65 - X XX - X X Z XXX

INFINITY
RECEPTACLE

STYLE

B = R/A SMT, 2 LOCATION
AND 4 SOLDERING POSTS
E = R/A SMT, 2 LOCATION
AND 4 SCREW MOUNT HOLES

CONNECTOR TYPE

04 = 4X
12 = 12X

PLATING

1 = 50μ" GOLD
2 = 30μ" GOLD
3 = GOLD FLASH OVER
PALLADIUM-NICKEL (LEAD FREE)
4 = 50μ" GOLD (RoHS COMPLIANT)
5 = 30μ" GOLD (RoHS COMPLIANT)

OPTION

0= 2 PIECE LOCKING PLATE (SHIPPED LOOSE)
1= ONE PIECE LOCKING PLATE (SHIPPED LOOSE)
2= NO LOCKING PLATE

PACKAGING/SPECIAL

NO DIGIT = TRAY PACKAGING
NO REAR COVER
C = TRAY PACKAGING
WITH REAR COVER (SHIPPED LOOSE)
T = TAPE & REEL PACKAGING
NO REAR COVER
CT = TAPE & REEL PACKAGING
WITH REAR COVER (SHIPPED LOOSE)

KEYING OPTION

0 = NO KEYING (STD)

MOUNTING STYLE

LANYARD LATCH (WITH TOP MOUNTING EAR)

1. MATERIAL:

PLASTIC HOUSING:

HIGH TEMPERATURE RESISTANT NYLON, FLAMMABILITY RATING UL94V-0.

CONTACTS:

PHOSPHOR BRONZE

PLATING OPTION (50μ" OR 30μ" GOLD):

50μ" [1.27 μm] OR 30μ" [0.76 μm] MIN. GOLD OVER 50μ" [1.27 μm] MIN. NICKEL ON CONTACT MATING SURFACES. 150μ" [3.81 μm] MIN. TIN-LEAD (90/10) OVER 50μ" [1.27 μm] NICKEL ON CONTACT TAILS.

PLATING OPTION (GOLD FLASH OVER PALLADIUM-NICKEL):

2μ" [0.05 μm] MIN. GOLD OVER 25μ" [0.635 μm] MIN. PALLADIUM-NICKEL ON CONTACT MATING SURFACES. 0.3μ" [0.007 μm] MIN. GOLD OVER 1.2μ" [0.03 μm] MIN. PALLADIUM-NICKEL ON CONTACT TAILS. 50μ" [1.27 μm] MIN. NICKEL UNDER PLATING.

PLATING OPTION (RoHS) (50μ" OR 30μ" GOLD):

50μ" [1.27 μm] OR 30μ" [0.76 μm] MIN. GOLD OVER 50μ" [1.27 μm] MIN. NICKEL ON CONTACT MATING SURFACES. 2μ" [0.05 μm] MIN. GOLD OVER 50μ" [1.27 μm] MIN. NICKEL ON CONTACT TAILS.

METAL SHELL:

DIE CASTING ALLOY

PLATING:

100μ" [2.54 μm] MIN. NICKEL OVER COPPER UNDER LAYER

GASKET:

STAINLESS STEEL

LOCKING PLATE:

STAINLESS STEEL

2. TEMPERATURE RANGE:

-40°C TO +85°C

DRAWN	L.DENG	DATE	2005/01/07
DESIGNED			
CHECKED	J.SI	DATE	2005/01/07
I. E. APPRD.			
Q. A. APPRD.			
DWG. APPRD.			
ENG. REL. NO.			
REF.	EAR# 12571/12614		
DIMENSIONS ARE IN	CODE ID. NO.		
INCHES [mm]	03554		

Amphenol Canada Corp.

TITLE INFINITY 4X/12X RECEPTACLE, LANYARD LATCH
FIXED BOARD, RIGHT ANGLE SMT
WITH TOP MOUNTING EAR

DWG	DRAWING NO.	REV.
A	P-U65-XXX-XX7XXX	B
SCALE	2/1	WT. -----
SURF.	-----	SHEET 1 of 4

THIS DOCUMENT CONTAINS PROPRIETARY INFORMATION AND SUCH INFORMATION
MAY NOT BE DISCLOSED TO OTHERS FOR ANY PURPOSE OR USED FOR MANUFACTURING
PURPOSES WITHOUT WRITTEN PERMISSION FROM AMPHENOL CANADA CORP.

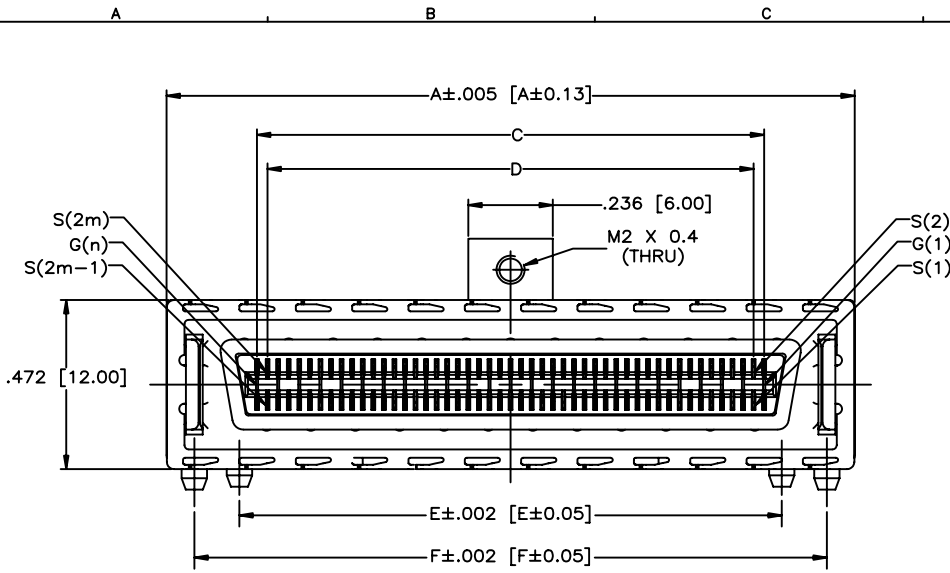

U65-BXX-XX7XXX
(LOCK PLATE REMOVED)

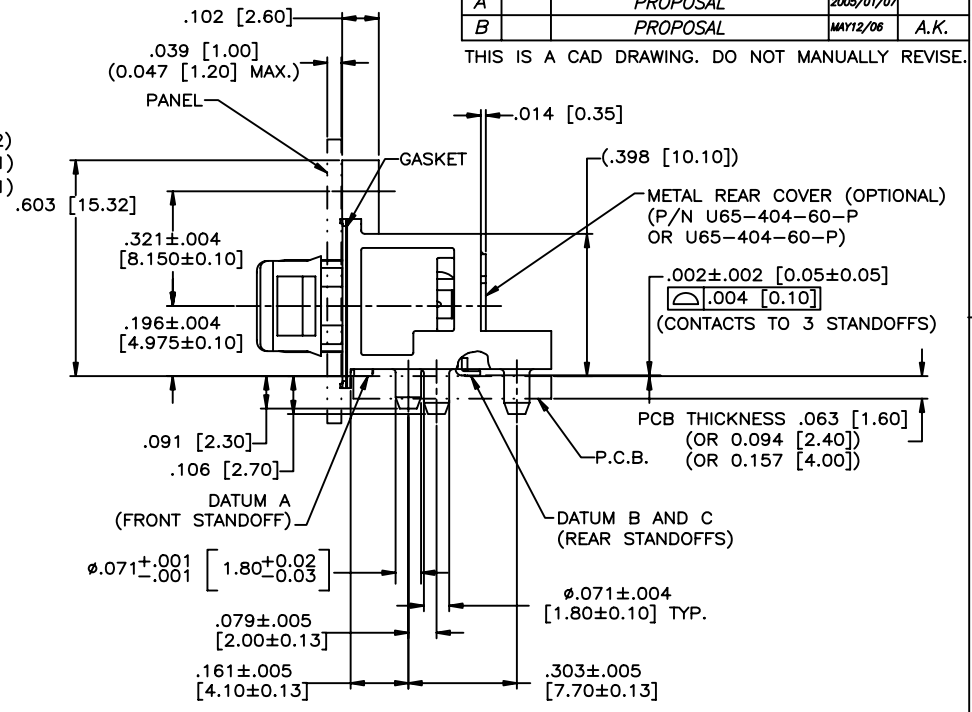

U65-BXX-XX7XXX
(SOLDER POST)

DIMENSION TABLE:

PART NUMBER	U65-X04-XX7XXX	U65-X12-XX7XXX
A	.978 [24.85]	1.923 [48.85]
B	.776 [19.70]	1.720 [43.70]
C	.472 [12.00]	1.417 [36.00]
D	.413 [10.50]	1.358 [34.50]
E	.571 [14.50]	1.516 [38.50]
F	.823 [20.90]	1.768 [44.90]
G	.736 [18.70]	1.681 [42.70]
H	.894 [22.70]	1.839 [46.70]
K	.776 [19.70]	1.720 [43.70]
m	m = 1 - 8	m = 1 - 24
n	n = 1 - 9	n = 1 - 25

** REFER TO [mm] AS PRIMARY DIMENSIONS.

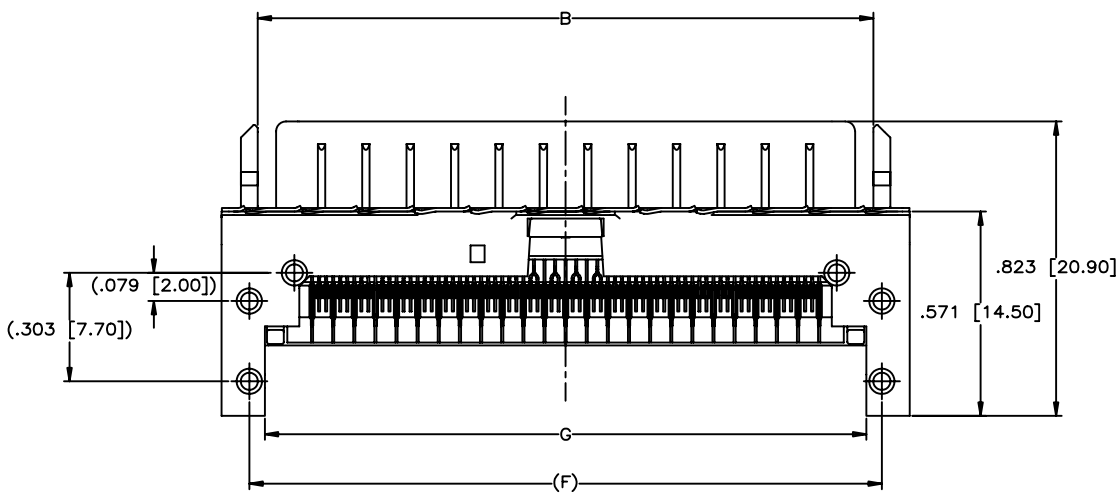

U65-BXX-XX7XXX
(LOCK PLATE REMOVED)

REVISIONS				
SYM	ZONE	ECN, ERN NO.	DATE	APPRD.
A		PROPOSAL	2005/01/07	
B		PROPOSAL	MAY12/06	A.K.

THIS IS A CAD DRAWING. DO NOT MANUALLY REVISE.

DRAWN	L.DENG	DATE	2005/01/07
DESIGNED			
CHECKED	J.SI	DATE	2005/01/07
I. E. APPRD.			
Q. A. APPRD.			
DWG. APPRD.			
ENG. REL. NO.			
REF.	EAR# 12571/12614		
DIMENSIONS ARE IN	CODE ID. NO.		
INCHES [mm]	03554		

Amphenol Canada Corp.
 TITLE INFINITY 4X/12X RECEPTACLE, LANYARD LATCH
 FIXED BOARD, RIGHT ANGLE SMT
 WITH TOP MOUNTING EAR

DWG	DRAWING NO.	REV.
A	P-U65-XXX-XX7XXX	B
SCALE	2/1	WT. _____
SURF.	_____	SHEET 2 OF 4

THIS DOCUMENT CONTAINS PROPRIETARY INFORMATION AND SUCH INFORMATION MAY NOT BE DISCLOSED TO OTHERS FOR ANY PURPOSE OR USED FOR MANUFACTURING PURPOSES WITHOUT WRITTEN PERMISSION FROM AMPHENOL CANADA CORP.

A B C D E F

REVISIONS				
SYM	ZONE	ECN, ERN NO.	DATE	APPRD.
A		PROPOSAL	2005/01/07	
B		PROPOSAL	MAY12/06	A.K.

THIS IS A CAD DRAWING. DO NOT MANUALLY REVISE.

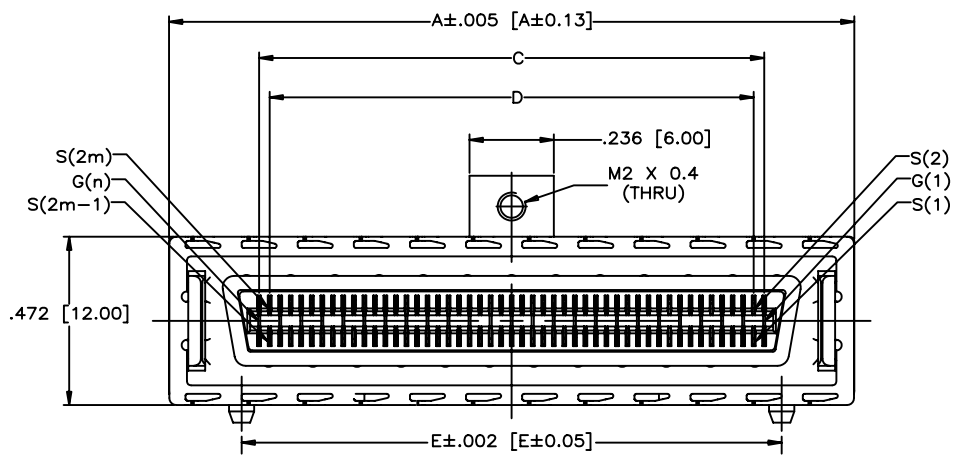

U65-EXX-XX7XXX
(LOCK PLATE REMOVED)

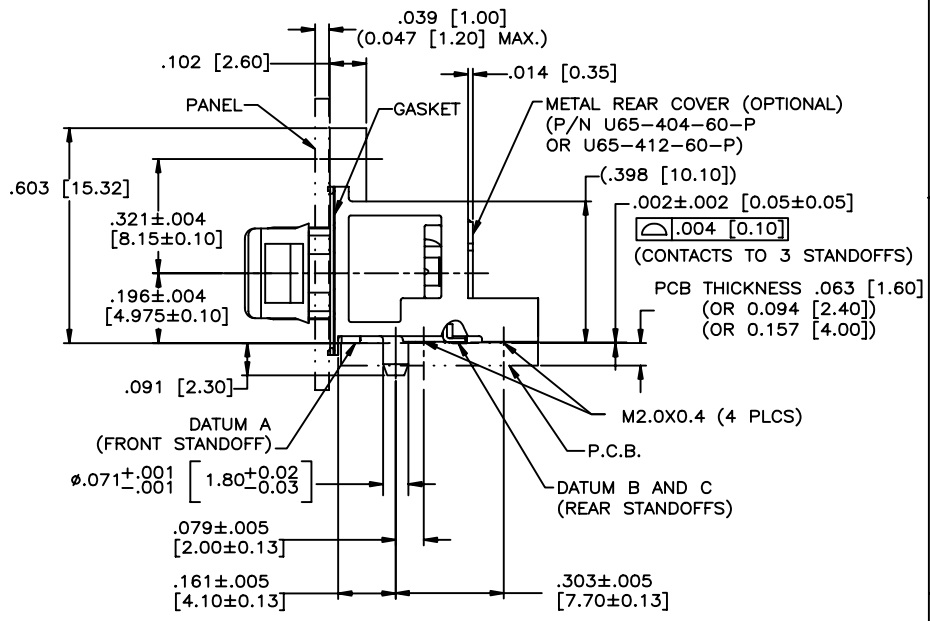

U65-EXX-XX7XXX
(SCREW MOUNT)

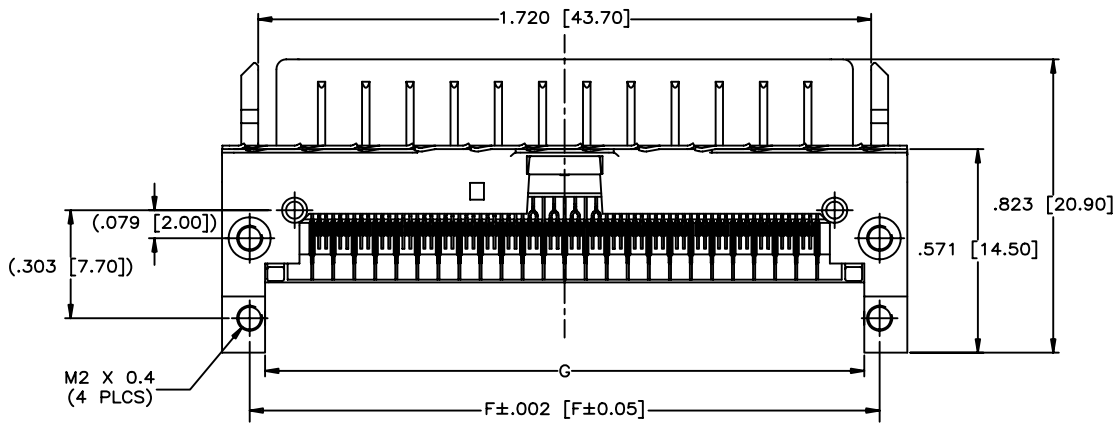

U65-EXX-XX7XXX
(LOCK PLATE REMOVED)

** REFER TO [mm] AS PRIMARY DIMENSIONS.

DRAWN	L.DENG	DATE	2005/01/07
DESIGNED			
CHECKED	J.SI	DATE	2005/01/07
I. E. APPRD.			
Q. A. APPRD.			
DWG. APPRD.			
ENG. REL. NO.			
REF.	EAR# 12571/12614		
DIMENSIONS ARE IN	INCHES [mm]	CODE ID. NO.	03554

Amphenol Canada Corp.			
TITLE INFINITY 4X/12X RECEPTACLE, LANYARD LATCH FIXED BOARD, RIGHT ANGLE SMT WITH TOP MOUNTING EAR			
DWG	DRAWING NO.	REV.	
A	P-U65-XXX-XX7XXX	B	
SCALE	2/1	WT.	
SURF.		SHEET	3 OF 4

THIS DOCUMENT CONTAINS PROPRIETARY INFORMATION AND SUCH INFORMATION MAY NOT BE DISCLOSED TO OTHERS FOR ANY PURPOSE OR USED FOR MANUFACTURING PURPOSES WITHOUT WRITTEN PERMISSION FROM AMPHENOL CANADA CORP.

REVISIONS				
SYM	ZONE	ECN, ERN NO.	DATE	APPRD.
A		PROPOSAL	2005/01/07	
B		PROPOSAL	MAY12/06	A.K.

THIS IS A CAD DRAWING. DO NOT MANUALLY REVISE.

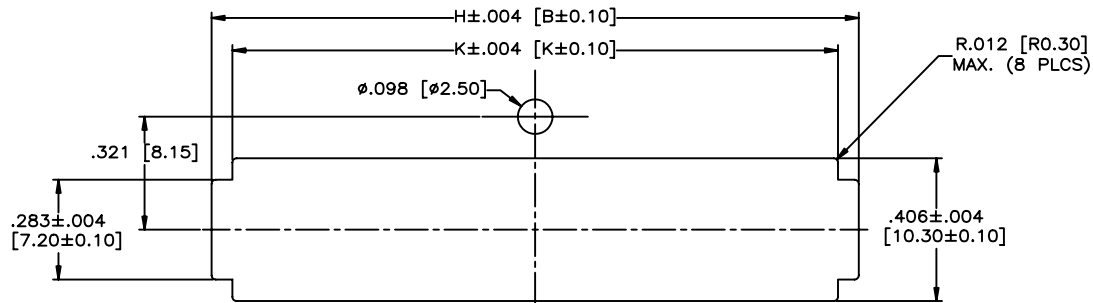

RECOMMENDED PANEL CUTOUT

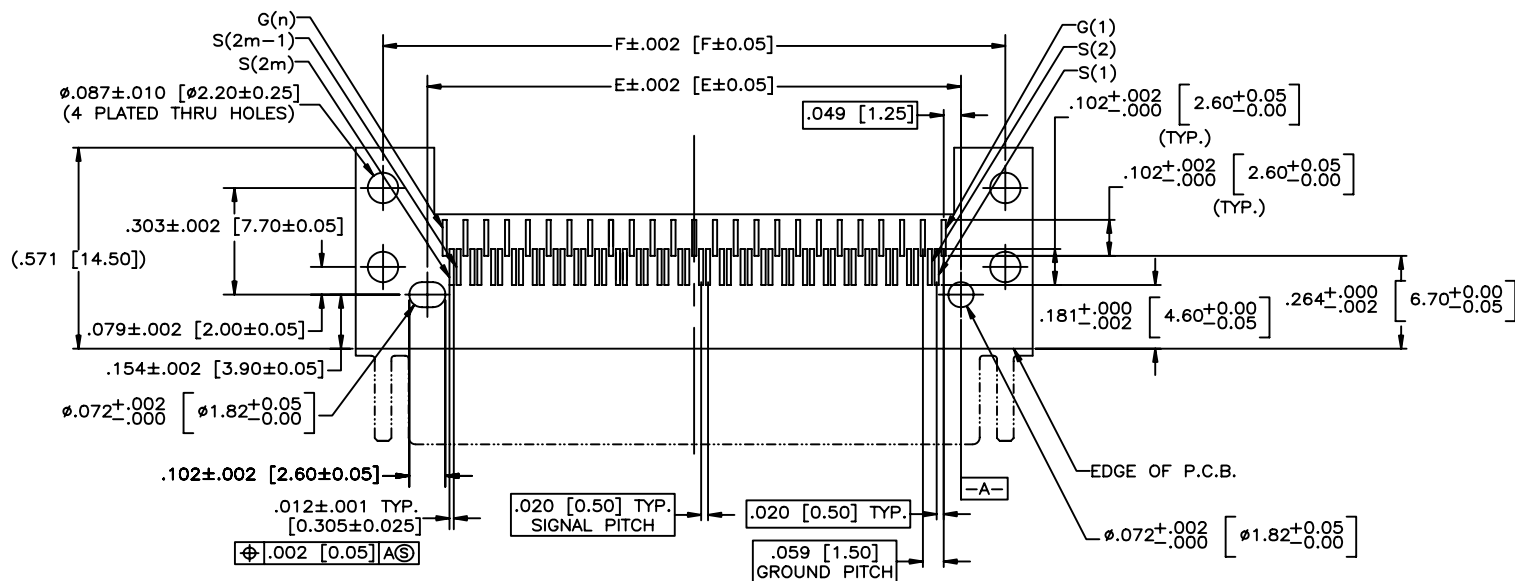

RECOMMENDED P.C.B. LAYOUT
(COMPONENTS SIDE OF BOARD)

** REFER TO [mm] AS PRIMARY DIMENSIONS.

DRAWN	L.DENG	DATE	2005/01/07
DESIGNED			
CHECKED	J.SI	DATE	2005/01/07
I. E. APPRD.			
Q. A. APPRD.			
DWG. APPRD.			
ENG. REL. NO.			
REF.	EAR# 12571/12614		
DIMENSIONS ARE IN	INCHES [mm]	CODE ID. NO.	03554

Amphenol Canada Corp.

TITLE INFINITY 4X/12X RECEPTACLE, LANYARD LATCH
FIXED BOARD, RIGHT ANGLE SMT
WITH TOP MOUNTING EAR

DWG	DRAWING NO.	REV.
A	P-U65-XXX-XX7XXX	B
SCALE	2/1	WT. _____ SURF. _____ SHEET 4 OF 4

THIS DOCUMENT CONTAINS PROPRIETARY INFORMATION AND SUCH INFORMATION
MAY NOT BE DISCLOSED TO OTHERS FOR ANY PURPOSE OR USED FOR MANUFACTURING
PURPOSES WITHOUT WRITTEN PERMISSION FROM AMPHENOL CANADA CORP.